

A 5B '8]YgY` / 'Hi fVc
@ , #* \$6

Engineering the Future – since 1758.

MAN Diesel & Turbo



A 5B '8]YgY` / 'Hi fVc
' 8!9b[]bY 'J]Yk Yf

J]Y`Yb '8 Ub_ Zf` Af` bhYfYggY` Ub`
i bgYfYb`A 5B '8]YgY` / 'Hi fVc` DfcXi` _hYb"

K]f`ZYi Yb`i bgz`AbYb`a]hXYa` " 8!9b[]bY`J]Yk Yf`Y]b`K Yf_nYi [`Ub`X]Y`<UbX
ni` [YVYbza]hk`Y`WYa` `G]Y`VYeI Ya`] cb`AfYa` `5fVY]rgd`Um`Ui`g`Y]bYb`A`ctcf
[Ya`A`>`AfYb`5bZcfXYfi b[Yb`_cbZ[i f]YfYb`_ObbYb"

K Ybb`G]Y: fU[Yb`UVYbz`_ObbYb`G]Y`g]M`g`Y`f[YfbY`Ub`i`bg`k`YbXYb.

A 5B '8]YgY` / 'Hi fVc
, * &&('5i [gVi f[z: Yfa Ubm
D\cbY`Z (- ; &%` &&!\$
: Ul`'s'sZ (- ; &%` &&!` ' , &
a Uf]bYYb[]bYg!XY4` a UbX]YgY`h`fVc`Wta
k k k "a UbX]YgY`h`fVc`Wta

8]gWU]a Yf

A]hXYa` `A 5B '8]YgY` / 'Hi fVc` " 8!9b[]bY`J]Yk Yf`_cbZ[i f]YfY`A`ctcfYb`_ObbYb
Zf`X]Y`[fi bXgAm]MXY`Dfc`Y`_hYfi b[] cb`A` UgW]bYbFUi` a` UbcfXbi b[Yb`Xi` fVX
ZUW`_j` bX][Yg`DYfgcbU`j` Yfk`YbXYhk`YfXYb`"8 Ug`XUf[Ygh`h`h`'8 Yg][b`gh`h`h`
_Y]bY`j` YffU[gfYWkh]MXY`J`YfY]bVUfi b[`XUfz]ghUVYf`Zf`j` cf] YffU[`]MXY
Dfc`Y`_hYfi b[gnk`YW`Y` \]bFY]MXYbX`[YbUi` "a` J`YffU[gZU`_`_Ubb`X]Y
6YfY]gh`h`i` b[`Ui` ZfU[ggdYn]ZgVWYf`" 8`D`Ubi b[ga`cXY`Y`]b`j` YfgW]YXYbYb
: cfa`Uh`b`j`YfY]bVUfhk`YfXYb`"J`YfV]bX`MXY`5Va` Yggi b[Yb`i` bX
5bgW`i` >]bZfa` Uh]cbYb`k`YfXYb`]a` `5i` ZfU[gZU`_`VYfY]f` Ygh`h`h`

5`XUHU`dfcj`]YX`]b`h]g`XcW` a` Ybh]g`bcb!V]bX]b[" `h\]g`XUHU`gYfj` Yg
]bZfa` Uh]cbU`di` fdcgYg`cb`m`UbX`]g`YgdYW]U`mbch[i` Uf]bhYX`]b`Ubm`k`Um`
8YdYbX]b[`]cb`h`Y`gi` VgYeI`YbhgdYW]W]bX]j`]Xi` U`dfc`Y`Wgz`h`Y`fY`Y` UbhXUHU
a`Um`VY`gi` V`Y`Wh`rc`W`Ub[Yg`UbX`k`]`VY`UggYggYX`UbX`XYH`fa`]bYX`]bX]j`]Xi` U`m`
Zf`YUW`dfc`Y`W`h`h\]g`k`]`XYdYbX`cb`h`Y`dUfh]W`Uf`W`UfUWY`f]gh]Wg`cZYUW
]bX]j`]Xi` U`dfc`Y`Wz`YgdYW]U`mgdYW]Z]Wg]h`Y`UbX`cdYfU]cbU`WcbX]h]cbg"

' 8!D8: / `J]Yk Yf`dck`YfYX`Vm7589B5G: a V<

' 8!5bg]W\ h
@ , # \$6

HYW b]gWY '8 UHY b

@(, #* \$6

A cfcf`Hmd	@(, #* \$6
Nm]bXYfj Uf]UbhY	*`Nm]bXYf
Hi fVc`UXYf	Hi fVc`UXYf?i dd'i b[ggY]hY
Hi fVc`UXYfmd	H75))
5i g`Ugg	a]h, VYf[Ub[gghØW_
, VYf[Ub[gghØW_	GhUbXUfX', VYf[Ub[gghØW_
F cHh]cb Hi fVc`UXYf	\$...
: U`Yf]Y	a]h: U`Yf]Y
@U[Yfi b[GhUffY`@U[Yfi b[
? fUzUvff]YV? : G	c\bY? fUzUvff]YV
5i gVUi fAi a Y	5i gVUi fAi a Y b]W.hg]W.hVUf
Di a dYb	U`Y`Di a dYb
@Y]gh b[+z&\$\$`_K`f)%(`f#b`]bE
J YfvfUi W	%+,`[#_K` \fA`7F`1`%\$\$i`E

&8!5bg]W\ hY b

@(, # \$6

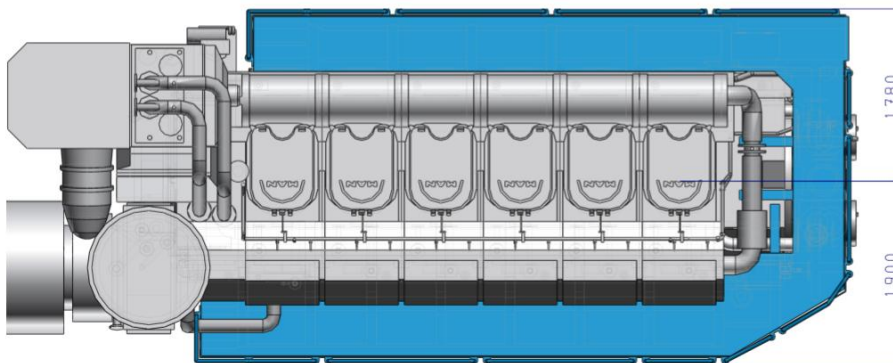
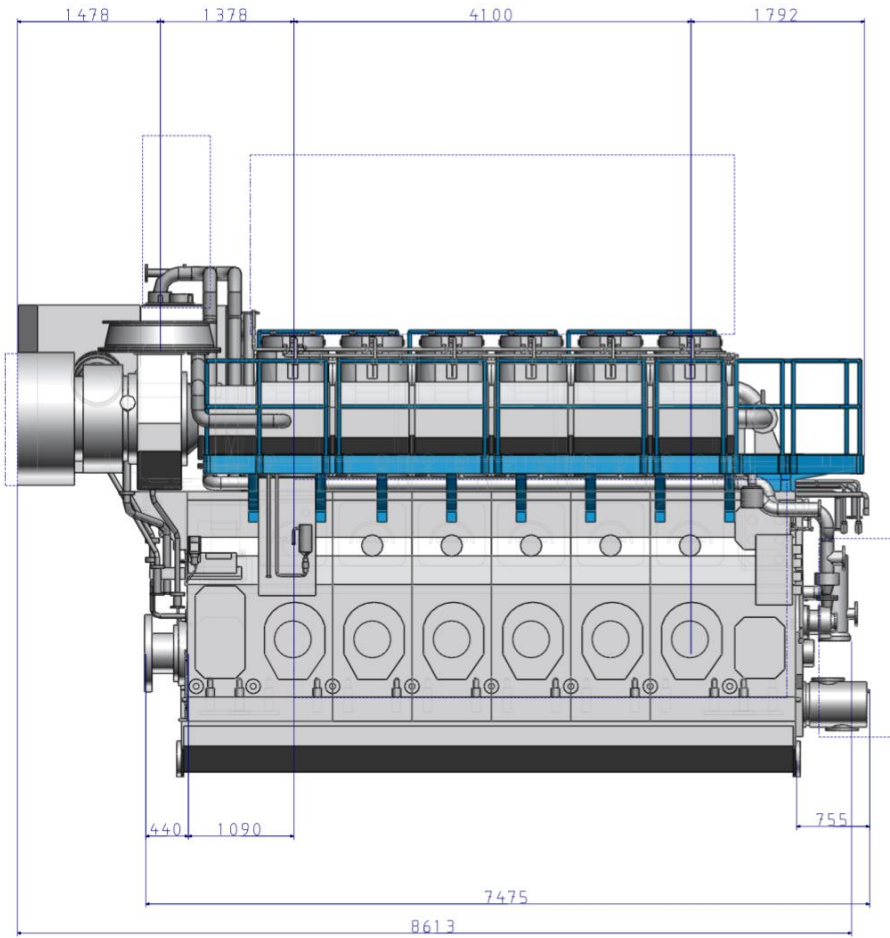

MAN Diesel & Turbo

86224 Augsburg, Germany

Phone +49 821 322-0

Fax +49 821 322-3382

marineengines-de@mandieselturbo.com

www.mandieselturbo.com